

Trade-Offs for Odd Gossiping

(Extended abstract)

Guillaume Fertin

LaBRI U.M.R. C.N.R.S. 5800, Université Bordeaux I
351 Cours de la Libération, F33405 Talence Cedex
fertin@labri.u-bordeaux.fr

Abstract

In the gossiping problem, each node of a network starts with a unique piece of information and must acquire the information of all the other nodes. This is done using two-way communications between pairs of nodes. In this paper, we consider gossiping in n -node networks with n odd, where we use a linear cost model, in which the cost of communication is proportional to the amount of information transmitted. We also assume a synchronous model, in which the pairwise communications are organized into rounds, and all communications in one round start at the same time. Each communication between two vertices during a given round uses a certain number of steps, each step being the time to exchange an indivisible piece of information. Fertin and Peters [FP98a] have given optimal gossip algorithms in the synchronous model for odd n when R_n , the number of rounds, is minimum ($R_n = \lceil \log_2(n) \rceil + 1$); that is, they have determined the minimum number of steps S_n that are used in a synchronous gossip algorithm with $\lceil \log_2(n) \rceil + 1$ rounds. As suggested in [FP94] and [FP98a], we study in this paper the trade-offs between R_n and S_n for odd n in the linear cost model in the synchronous case. We show several bounds on S_n (resp. on R_n) when the optimality condition on R_n (resp. S_n) is relaxed. We show that some of these bounds are tight for an infinite number of cases, and discuss such results.

Keywords : gossiping, linear cost model, trade-off, communication, networks.

1 Introduction

Gossiping is an information dissemination problem in which each node of a communication network has a piece of information that must be acquired by all the other nodes. Information is communicated between pairs of nodes using two-way communications or *calls* along the communication links of the network. Most of the papers dealing with gossiping assume a *unit cost* model in which a communication takes one time unit independent of the amount of information being transmitted. When messages are long, a *linear cost* model is more realistic since the length of the messages in most gossip algorithms grows exponentially.

In this paper, we assume a *store-and-forward, 1-port, full-duplex* model in which each communication involves two nodes and the single communication link that connects them, each node communicates with at most one other node at any given time, and information can flow simultaneously in both directions along a link. Each node starts with a message of length 1, and messages can be concatenated and sent as a single communication.

We assume a *linear cost* model in which the time to send a message of length k is $\beta + k\tau$ where β is the *start-up* time to initiate a call between a pair of nodes and τ is the *propagation* time of a message of length 1 along a link. If the two nodes involved in a call send messages of different lengths, then the time for both nodes to complete the call is determined by the length of the longer message. A call involving messages of length k can be thought of as a start-up period that takes time β followed by a sequence of k *steps* each of which takes time τ .

We also assume a *synchronous* model, in which a gossip algorithm consists of a sequence of *rounds* of simultaneous pairwise communications. All calls in a round start at the same time. Calls in a round may end at different times, depending on the lengths of the messages, but no node can start a new call until all nodes are ready to start new calls. Note that the unit cost model is always synchronous since each call takes one time unit.

Fraigniaud and Peters [FP94] investigated the structure of minimum-time gossip algorithms using a linear cost model. They established lower and upper bounds on the time to gossip when the number of nodes n is even and showed that there is a synchronous minimum-time gossip algorithm for every even n .

Knödel [Knö75] showed that gossiping in the unit cost model requires $\lceil \log_2(n) \rceil + 1$ rounds when n is odd. This lower bound on the number of rounds is also valid for the linear cost model in both the synchronous and asynchronous cases. It is also immediate that at least n steps are required because each node needs to acquire $n - 1$ pieces of information, and at least one node is idle (i.e., not involved in a communication) at any given time. This gives a lower bound of $\max\{(\lceil \log_2(n) \rceil + 1)\beta, n\tau\}$. Peters, Raabe, and Xu [PRX96] proved a lower bound of $(\lceil \log_2(n) \rceil + 1)\beta + n\tau$ for odd n for both the synchronous and asynchronous cases.

However, they proved stronger lower bounds for the synchronous case by fixing the number of rounds to be $\lceil \log_2(n) \rceil + 1$ and then focussing on the required number of steps. They also conjectured that these lower bounds are achievable for all odd n . This conjecture has been proved to be correct by Fertin and Peters [FP98a].

In this paper, we consider the possible trade-offs between the number of rounds R_n and the number of steps S_n for a synchronous gossip algorithm in a n -node network, n being odd (note that since Fraigniaud and Peters [FP94] showed that both R_n and S_n are optimal when n is even, studying such a trade-off in the even case does not make sense). The main question is the following : what can we say about S_n (resp. R_n) when we relax the optimality condition on R_n (resp. S_n) ? We then study, for any integer $r \geq 0$, the function $S_n(r)$ corresponding to the optimal number of steps for a gossip algorithm (in a n -node network) with $R_{min} + r$ rounds, where $R_{min} = \lceil \log_2(n) \rceil + 1$.

Similarly, we study, for any integer $s \geq 0$, the function $R_n(s)$, corresponding to the optimal number of rounds for a gossip algorithm (in a n -node network) which takes exactly $S_{min} + s$ steps, where $S_{min} = n$.

In Section 2.1, we give a general lower bound on $S_n(r)$ for any r and odd n . We will see that this bound includes the ones given by Peters et al. [PRX96] in the case $r = 0$, which are known to be tight (cf. [FP98a]). Section 2.2 is devoted to upper bounds for $S_n(r)$: first, we give a general upper bound for $S_n(1)$, and show the exact value of $S_{2^k-1}(1)$ for any $k \geq 3$. We also give a conjecture on an upper bound for $S_n(r)$ for any r and odd n .

In Section 3, we study the function $R_n(s)$. We show the exact value of $R_n(0)$, and give a general lower bound on $R_n(s)$ for any $s \geq 1$. We also show that this bound is tight for some particular cases of s and n . Finally, we discuss in Section 5 the results and the improvements of relaxing the optimality condition on either R_n or S_n .

2 Relaxing the condition on R_n

In this Section, we discuss the value of $S_n(r)$, the optimal number of steps of a gossip algorithm among n nodes taking $R_n = R_{min} + r$ rounds, where $R_{min} = \lceil \log_2(n) \rceil + 1$.

2.1 A general lower bound for $S_n(r)$

First, we recall a result from [FP98a]. Let R_{min} be the minimum number of rounds for a gossip algorithm among n nodes, n being odd. We know that $R_{min} = \lceil \log_2(n) \rceil + 1$, is the same for every

odd n between $2^{k-1} + 1$ and $2^k - 1$, where $k = \lceil \log_2(n) \rceil$. In a gossip algorithm that takes exactly R_{min} rounds, the required total number of steps and also the required numbers of steps in each of the rounds depends on whether n is in the *Bottom Half* of the range, $2^{k-1} < n < 2^{k-1} + 2^{k-2}$, or the *Top Half* of the range, $2^{k-1} + 2^{k-2} < n < 2^k$ (as shown in Theorem 1 below). We will often refer to the top halves of all ranges collectively as *the Top Half* and similarly for *the Bottom Half*.

Theorem 1 ([FP98a]) *For any odd n such that $\lceil \log_2(n) \rceil = k$, any gossip algorithm that takes $k + 1$ rounds takes exactly :*

- $2n - 2^{k-1} - 1$ steps if n is in the *Top Half* ;
- $n + \lfloor \frac{n-2^{k-2}}{2} \rfloor$ steps if n is in the *Bottom Half*.

Sketch of Proof : In [PRX96], Peters et al. gave a lower bound on the number of steps when the number of rounds is minimum (equal to $k + 1$). For this, they distinguished two cases : n is in the Bottom Half, or n is in the Top Half. Fertin and Peters [FP98a] then showed gossip algorithms in both the Bottom and Top Half which reach the lower bound on the number of steps. \square

We then know what is the minimum number of steps when the number of rounds is minimum, that is when $R_n = R_{min} = k + 1$. Now, we relax the condition of minimality for R_n . Suppose indeed that $R_n = R_{min} + r = k + 1 + r$, where r is an arbitrary positive integer, and let us study $S_n(r)$, the number of steps needed to gossip in a n -node network when $R_n = k + 1 + r$. First, note that $S_n(r + i) \leq S_n(r)$ for any positive integer i , since any gossip algorithm in $R_{min} + r$ rounds to which we add i “empty” rounds (that is, rounds where all the vertices are idle) remains a gossip algorithm with as many steps, and with i more rounds.

The following Theorem gives a general lower bound for $S_n(r)$.

Theorem 2 *For any odd n with $\lceil \log_2(n) \rceil = k$, let $R_n = k + 1 + r$ for any arbitrary r . For any $\alpha \geq 2$, let p and q be such that $n - 2^{k-\alpha+1} = (\alpha + r - 1) \cdot p + q$, with $0 \leq q \leq \alpha + r - 2$. Then :*

- If $q = 0$, for all $n \geq 2^{k-\alpha} \cdot (\alpha + r + 1)$, we have :

$$S_n(r) \geq 2^{k-\alpha+1} + (\alpha + r) \cdot p - 1$$

- If $q \neq 0$, for all $n \geq 2^{k-\alpha} \cdot (\alpha + r + 1) - ((\alpha + r - 1) - q)$, we have :

$$S_n(r) \geq 2^{k-\alpha+1} + (\alpha + r) \cdot p + q$$

Proof : The method here is based on the same principle as the one described for proving the lower bounds on $S_n(0)$ in [PRX96]. Here, we generalize the method, and we will show that this includes the result of [PRX96] for the particular case $r = 0$.

The idea is to give a sequence σ of $k + 1 + r$ sets of steps s_i ($1 \leq i \leq k + 1 + r$), each $|s_i|$ corresponding to the number of steps used in round i .

A necessary condition for σ to be valid for gossiping is the Basic Premise defined below. The Step Decreasing Property, also described below, implies that $\sum_{i=1}^{k+r+1} |s_i|$ is a lower bound for $S_n(r)$.

- The *Basic Premise* : for any round $1 \leq i \leq k + r + 1$, the sum of the number of steps in all the other rounds (that is, excluding round i) must be at least equal to $n - 1$. This comes from the fact that since n is odd, there is at least one idle vertex in round i . Hence we must have, for any sequence σ , and for any $1 \leq i \leq k + r + 1$, $\sum_{j=1, j \neq i}^{k+r+1} |s_j| \geq n - 1$.
- The *Step Decreasing Property* : for any round $1 \leq i \leq k + r + 1$, any decrease of 1 step in s_i implies an increase of at least one step in one or several s_j , with $j \neq i$.

Hence, if the Basic Premise and the Step Decreasing Property hold for the sequences σ which we will give below, then $S_n(r) \geq \sum_{i=1}^{k+r+1} |s_i|$.

In that case, we decide to choose a sequence σ which is as follows : during a certain number of rounds (precisely, during the first $k - \alpha + 1$ rounds), we use the maximum number of steps, that is 2^{i-1} steps for each round $1 \leq i \leq k - \alpha + 1$. Then, each of the remaining $\alpha + r$ rounds will contain approximately the same number of steps. More precisely, we choose an integer $\alpha \geq 2$, and define p and q to be such that $n - 2^{k-\alpha+1} = (\alpha + r - 1) \cdot p + q$ (with $0 \leq q < \alpha + r - 1$). That is, $p = \lfloor \frac{n-2^{k-\alpha+1}}{\alpha+r-1} \rfloor = \frac{n-2^{k-\alpha+1}-q}{\alpha+r-1}$.

Depending on the value of α that we choose, the total number of steps of such a sequence, as well as the range of values of n for which it is valid, may vary. But, in general, the aim is to find, for fixed r and (odd) n , the smallest α such that the steps sequence verifies both the Basic Premise and the Step Decreasing Property.

Now, let us distinguish two cases, depending on the value of q :

- $q = 0$. In that case, we consider the sequence :

$$\underbrace{1 \ 2 \ 4 \ \dots \ 2^{k-\alpha}}_{k-\alpha+1 \text{ Rounds}} \quad \underbrace{p \ p \ p \ \dots \ p}_{\alpha+r \text{ Rounds}}$$

Let us check that the Basic Premise and the Step Decreasing Property both hold.

- The Basic Premise implies that for any $0 \leq i \leq k - \alpha$, we must have $2^{k-\alpha+1} - 1 - 2^i + (\alpha + r) \cdot p \geq n - 1$ **(I1)**, and $2^{k-\alpha+1} - 1 + (\alpha + r - 1) \cdot p \geq n - 1$ **(I2)**. Since $(\alpha + r - 1) \cdot p = n - 2^{k-\alpha+1}$, **(I2)** always holds. Multiplying the left and right members of **(I1)** by $(\alpha + r - 1)$ finally gives $n \geq 2^{k-\alpha+1} + (\alpha + r - 1) \cdot 2^i$ for any $0 \leq i \leq k - \alpha$. Since we supposed $n \geq 2^{k-\alpha} \cdot (\alpha + r + 1)$, we know that **(I1)** is always true too, and we conclude that the Basic Premise holds for this particular sequence of steps.
- The Step Decreasing Property : suppose that the number of steps $|s_i|$ is decreased by 1, for an arbitrary $1 \leq i \leq k + r + 1$. Suppose no other $s_{i'}$ ($i' \neq i$) is changed. Now look at a vertex which is idle at any round $j \neq i$ among the last $\alpha + r$ rounds (we know there exists such a vertex, since $\alpha \geq 2$). In order for this vertex to be able to gather the information of all the other vertices, we must have $\sum_{i=1}^{k+r+1} |s_i| - p - 1 \geq n - 1$. However, $\sum_{i=1}^{k+r+1} |s_i| - 1 - p = 2^{k-\alpha+1} - 1 + (\alpha + r - 1) \cdot p - 1$. Since $(\alpha + r - 1) \cdot p = n - 2^{k-\alpha+1}$, this gives $n - 2 \geq n - 1$. Hence the contradiction. This means that any decrease of 1 step in any s_i ($1 \leq i \leq k + r + 1$) implies an increase of at least one step at another place.

Hence, $\sum_{i=1}^{k+r+1} |s_i| = 2^{k-\alpha+1} + (\alpha + r) \cdot p - 1$ is a lower bound for $S_n(r)$ when $q = 0$.

- $q \neq 0$. In that case, consider the sequence :

$$\underbrace{1 \ 2 \ 4 \ \dots \ 2^{k-\alpha}}_{k-\alpha+1 \text{ Rounds}} \quad \underbrace{p \ p \ \dots \ p \ \overbrace{(p+1) \ (p+1) \ \dots \ (p+1)}^{q+1 \text{ Rounds}}}_{\alpha+r \text{ Rounds}}$$

Now, let us check that the Basic Premise and the Step Decreasing Property hold.

- The Basic Premise implies that for any $0 \leq i \leq k - \alpha$, we must have $2^{k-\alpha+1} - 1 - 2^i + (\alpha + r) \cdot p + (q + 1) \geq n - 1$ **(I1)**, and $2^{k-\alpha+1} - 1 + (\alpha + r - 1) \cdot p + q \geq n - 1$ **(I2)**. Since $(\alpha + r - 1) \cdot p + q = n - 2^{k-\alpha+1}$, **(I2)** always holds. Multiplying the left and right members of **(I1)** by $(\alpha + r - 1)$ finally gives $n \geq 2^{k-\alpha+1} + (\alpha + r - 1) \cdot 2^i + (q - \alpha + r - 1)$

for any $0 \leq i \leq k - \alpha$. Since we supposed $n \geq 2^{k-\alpha} \cdot (\alpha + r + 1) - ((\alpha + r - 1) - q)$, we know that (I1) is always true too, and we conclude that the Basic Premise holds for this particular sequence of steps.

- The Step Decreasing Property : suppose that the number of steps $|s_i|$ is decreased by 1, for an arbitrary $1 \leq i \leq k + r + 1$. Suppose no other $s_{i'}$ ($i' \neq i$) is changed. Now look at a vertex which is idle in any round $j \neq i$ among the last $q + 1$ rounds (we know there exists such a vertex, since $q + 1 \geq 2$). In order for this vertex to be able to gather the information of all the other vertices, we must have $\sum_{i=1}^{k+r+1} |s_i| - p - 2 \geq n - 1$. However, $\sum_{i=1}^{k+r+1} |s_i| - 1 - p = 2^{k-\alpha+1} - 1 + (\alpha + r - 1) \cdot p + q - 1$. Since $(\alpha + r - 1) \cdot p + q = n - 2^{k-\alpha+1}$, this gives $n - 2 \geq n - 1$. Hence the contradiction. This means that any decrease of 1 step in any s_i ($1 \leq i \leq k + r + 1$) implies an increase of at least one step at another place.

Hence, $\sum_{i=1}^{k+r+1} |s_i| = 2^{k-\alpha+1} + (\alpha + r) \cdot p + q$ is a lower bound for $S_n(r)$ when $q \neq 0$.

Collectively, the results given above for $q = 0$ and $q \neq 0$ prove the Theorem. \square

Remark 1 *Theorem 2 above includes the lower bounds given in [PRX96] for $r = 0$, for n in the Bottom Half as well as in the Top Half. Indeed, taking $\alpha = 2$ gives the lower bound (and steps sequence) given in [PRX96] for n in the Top Half, while $\alpha = 3$ applies for the whole range $[2^{k-1} + 1; 2^k - 1]$ and, in particular, gives the lower bound and steps sequence given in [PRX96] for n in the Bottom Half.*

This also proves that the general lower bound for $S_n(r)$ given in Theorem 2 is tight for every odd n when $r = 0$, thanks to the results of [FP98a]. We will see in Proposition 1 that it is also tight for the particular case $r = 1$ and $n = 2^k - 1$.

2.2 Upper bounds for $S_n(r)$

2.2.1 The case $r = 1$

We have the following general upper bound for $S_n(1)$.

Theorem 3 *For all odd n , let $bot(n) = 1$ if n is in the Bottom Half, and $bot(n) = 0$ otherwise. We have : $S_n(1) \leq 5 \cdot \lfloor \frac{n}{4} \rfloor + 4 + bot(n)$.*

Proof : Let us consider an odd integer n in the range $[2^{k-1} + 1; 2^k - 1]$. We know that n is either of the form $n = 4m + 1$, or of the form $n = 4m + 3$. Moreover, if n is in the Top Half (resp. the Bottom Half), so is m . Let us distinguish those two cases, and suppose first that n is in the Top Half.

When n is in the Top Half, we consider the following steps sequence :

$$\underbrace{1 \ 2 \ 4 \ \dots \ 2^{k-4}}_{k-3 \text{ Rounds}} \ x_T \ (m+1) \ (m+1) \ (m+1) \ (m+1)$$

where $x_T = m + 1 - 2^{k-3}$.

Note that the number of rounds used is $k + 2$, that is $r = 1$. Moreover, one can see that for this sequence, the Basic Premise holds. Now let us prove that we can find a gossip algorithm in $k + 2$ rounds which respects this steps sequence.

The idea here is to split the set V of vertices in four subsets V_i ($1 \leq i \leq 4$). If $n = 4m + 3$ (resp. $n = 4m + 1$), three of them will be of cardinality $m + 1$ (resp. of cardinality m), and one will be of cardinality m (resp. of cardinality $m + 1$). Four cases then arise, depending of the form of n ($n = 4m + 1$ or $n = 4m + 3$) and the parity of m . For each of these cases, the idea is to gossip independently in each V_i during the first $k - 2$ rounds when $|V_i|$ is even, or the first $k - 1$ rounds when $|V_i|$ is odd. Then, we use the remaining rounds to exchange information between the V_i .

In order to show that this is feasible, it is necessary to detail the four possible cases ; for each of them, we need to show that the 3 following conditions are fulfilled :

- Every V_i such that $|V_i|$ is even can achieve gossiping in $k - 2$ rounds with the steps sequence $1\ 2\ 4\ \dots\ 2^{k-4}\ x_T$ **(C1)** ;
- Every V_i such that $|V_i|$ is odd can achieve gossiping in $k - 1$ rounds with the steps sequence $1\ 2\ 4\ \dots\ 2^{k-4}\ x_T\ (m + 1)$ **(C2)** ;
- During the last four rounds, each of which taking $(m + 1)$ steps, it is possible to communicate between the V_i in such a way that gossiping is achieved after the $(k + 2)$ -th round **(C3)** .

We are going to prove here that conditions **(C1)** and **(C2)** always hold. The proof of Condition **(C3)** consists in giving, in each of the four cases, an *ad hoc* algorithm fulfilling the requirement ; it is omitted in this paper.

First, note that $\lceil \log_2(m) \rceil = k - 2$, and that when $|V_i|$ is even (resp. odd), we have $|V_i| = m + \text{odd}(m)$ (resp. $|V_i| = m + 1 - \text{odd}(m)$), where $\text{odd}(m) = 1$ if m is odd, and 0 otherwise. Moreover, we know that m is in the Top Half. To prove **(C1)**, it suffices to show that $2^{k-3} - 1 + x_T \geq (m + \text{odd}(m)) - 1$. Since $x_T = m + 1 - 2^{k-3}$, we see that this is always true. In order to prove that **(C2)** always holds, we need to show that the steps sequence corresponding to the first $k - 1$ rounds allows to achieve gossiping within the $m + 1 - \text{odd}(m)$ vertices. We know by [FP98a] that the sequence $1\ 2\ 4\ \dots\ 2^{k-4}\ x\ x$, where $x = (m + 1 - \text{odd}(m)) - 2^{k-3}$, works in that case, since m is in the Top Half. Hence, it suffices to prove here that $x_T \geq x$ and $m + 1 \geq x$ in all the cases. By definition of x_T , we see that $x = x_T - \text{odd}(m)$, and $x = (m + 1) - (\text{odd}(m) + 2^{k-3})$. This proves that **(C2)** always holds too.

Hence, we show that there exists a gossip algorithm taking $k + 2$ rounds and which follows the steps sequence above for any n in the Top Half. This proves that $S_n(1) \leq \sum_{i=1}^{k+2} |s_i|$. Since $\sum_{i=1}^{k+2} |s_i| = 5m + 4$ and $m = \lfloor \frac{n}{4} \rfloor$, the result is proved for any n in the Top Half.

When n is in the Bottom Half, we consider the following steps sequence :

$$\underbrace{1\ 2\ 4\ \dots\ 2^{k-5}}_{k-4\ \text{Rounds}}\ y_B\ (y_B + \text{odd}(m))\ (m + 1)\ (m + 1)\ (m + 1)\ (m + 1)$$

$$\text{where } y_B = \frac{m+2-\text{odd}(m)-2^{k-4}}{2}.$$

Note that the number of rounds in the above sequence is $k + 2$, that is $r = 1$. Moreover, the Basic Premise holds as well. Now let us prove that we can find a gossip algorithm taking $k + 2$ rounds and respecting the steps sequence above.

For this, we will use the Proof for n in the Top Half. Indeed, the above steps sequence differs from the one in the Top Half only for two of them, namely y_B and $y_B + \text{odd}(m)$, which, in the Top Half, were respectively 2^{k-4} and x_T . Hence, if we prove that such a steps sequence allows each V_i to achieve gossiping independently in $k - 2$ rounds (when $|V_i|$ is even) or $k - 1$ rounds (when $|V_i|$ is odd), the Theorem is proved ; indeed the gossip algorithms which apply in the Top Half would remain valid, concerning the last 4 rounds, in the Bottom Half, and this would show the result.

For this, we note the following :

- When $|V_i|$ is even (that is $|V_i| = m + \text{odd}(m)$), we must show that the sum of the number of steps over the first $k - 2$ rounds is at least equal to $|V_i| - 1$. This leads to $y_B + y_B + \text{odd}(m) + 2^{k-4} - 1 \geq |V_i| - 1$. However, standard calculations give $y_B + y_B + \text{odd}(m) + 2^{k-4} - 1 = m + 1$, and $|V_i| \leq m + 1$ by definition.
- When $|V_i|$ is odd, that is $|V_i| = m + 1 - \text{odd}(m)$, we know that $m + 1 - \text{odd}(m)$ is in the Bottom Half and $\lceil \log_2(m + 1 - \text{odd}(m)) \rceil = k - 2$. In that case, we know by [FP98a] that gossiping can be achieved in $k - 1$ rounds following the steps sequence $1\ 2\ \dots\ 2^{k-5}\ \gamma_1\ \gamma_2\ \gamma_3$, where 2 of the γ_i are equal to $z = \frac{(m+1-\text{odd}(m))+1-2^{k-4}}{2}$, and where the remaining γ_j is equal

to $z - 1$. Hence, we need to show that $\min\{y_B, y_B + \text{odd}(m), m + 1\} \geq z$. However, it is easy to see that $y_B = z$ and $m + 1 \geq z$ for any m .

Since the two conditions above are fulfilled, we can use the last 4 rounds of the gossip algorithm from the Top Half to achieve gossiping in $k + 2$ rounds, and with the required sequence of steps. This proves the Theorem for any n in the Bottom Half as well : indeed, $S_n(1) \leq \sum_{i=1}^{k+2} |s_i|$, and we have $\sum_{i=1}^{k+2} |s_i| = 5m + 5$ with $m = \lfloor \frac{n}{4} \rfloor$.

We have seen that the result also holds for any n in the Top Half, hence we conclude that $S_n(1) \leq 5 \cdot \lfloor \frac{n}{4} \rfloor + 4 + \text{bot}(n)$ for any odd n , where $\text{bot}(n)$ is equal to 1 if n is in the Bottom Half, and equal to 0 otherwise. \square

Proposition 1 *For any $n = 2^k - 1$ with $k \geq 3$, $S_n(1) = 5 \cdot 2^{k-2} - 2$.*

Proof: First, note that Theorems 2 and 3 give the following bounds for $S_{2^k-1}(1)$: $5 \cdot 2^{k-2} - 2 \leq S_{2^k-1}(1) \leq 5 \cdot 2^{k-2} - 1$. We are going to prove here that it is possible to meet the lower bound, thanks to the following steps sequence σ :

$$1 \ 2 \ 4 \ \dots \ 2^{k-3} \ (2^{k-2} - 1) \ 2^{k-2} \ 2^{k-2} \ 2^{k-2}$$

Note that this sequence is very similar to the one given in Proof of Theorem 3, where n is in the Top Half, of the form $n = 4m + 3$ with odd $m = 2^{k-2} - 1$. In that case, we have $x_T = 2^{k-3}$, and the only difference between the two steps sequences lie in the $(k - 1)$ -th round, where we use here $m = 2^{k-2} - 1$ steps, instead of $(m + 1)$. One can see that the Basic Premise holds for such a sequence. Moreover, the gossip scheme given in Figure 1 shows that it is possible to achieve gossiping in $(k + 2)$ rounds, with respect to the above steps sequence.

Indeed, let us split the set V of $n = 2^k - 1$ vertices in 4 subsets V_i ($1 \leq i \leq 4$), where $|V_1| = |V_2| = |V_3| = m + 1 = 2^{k-2}$ and where $|V_4| = m = 2^{k-2} - 1$. During the first $(k - 2)$ rounds, let each block V_i , with $1 \leq i \leq 3$, gossip independently. Since each of the first $(k - 2)$ rounds has a maximum number of steps, and since $|V_i| = 2^{k-2}$, we know that, after round $(k - 2)$, each vertex of V_i ($1 \leq i \leq 3$) is expert of V_i (we say that a node is *expert* of a set V if it knows the information of every node in V). V_4 will need one more round in order for all its vertices to be experts of V_4 . We know that after round $k - 1$, all vertices of V_4 will be experts of V_4 , since the needed steps sequence for any vertex of V_4 is $1 \ 2 \ 4 \ \dots \ 2^{k-4} \ (2^{k-3} - 1) \ (2^{k-3} - 1)$ [PRX96], and since $m = 2^{k-2} - 1 \geq 2^{k-3} - 1$. Hence, following this steps sequence, any vertex of V_4 will be expert of V_4 after $(k - 1)$ rounds. Finally, note that since $|V_4|$ is odd, there is at least one vertex u idle in V_4 during round $(k - 1)$. This vertex is necessarily expert of V_4 after round $k - 2$. The idea here is to make u communicate with a vertex v of V_3 during round $(k - 1)$, while the other vertices of V_4 communicate within their own subset, and while the vertices of V_1 communicate with the vertices of V_2 .

The algorithm is illustrated in Figure 1. The column of 4 boxes with bold outlines on the left shows the situation after $k - 2$ rounds, each of which having the maximum number of steps (that is 2^{i-1} steps for any round $1 \leq i \leq k - 2$). Rounds $k - 1$ to $k + 2$ are shown in detail and the box on the right shows the situation after round $k + 2$.

This shows that the steps sequence above allows to achieve gossiping in $(k + 2)$ rounds. Hence $S_{2^k-1}(1) \leq 5 \cdot 2^{k-2} - 2$, which, combined with the results of Theorem 2, gives the result. \square

Remark 2 *This proves that the upper bound of $5 \cdot \lfloor \frac{n}{4} \rfloor + 4 + \text{bot}(n)$ given in Theorem 3 is not tight for an infinity of values of n (namely, $n = 2^k - 1$ with $k \geq 3$) when $r = 1$. However, we see that the lower bound given in Theorem 2 is tight for the same values of r and n .*

2.2.2 The case $r = 2^d - d - 1$

Conjecture 1 *Let r be a fixed positive integer. Let d be the greatest integer such that $r \geq 2^d - d - 1$. Then, for any odd n , $S_n(r) \leq (r + d + 2) \cdot \lfloor \frac{n}{r+d+1} \rfloor + (r + d + 1) + \text{bot}(n)$, where $\text{bot}(n)$ is equal to 1 when n is in the Bottom Half, and 0 otherwise.*

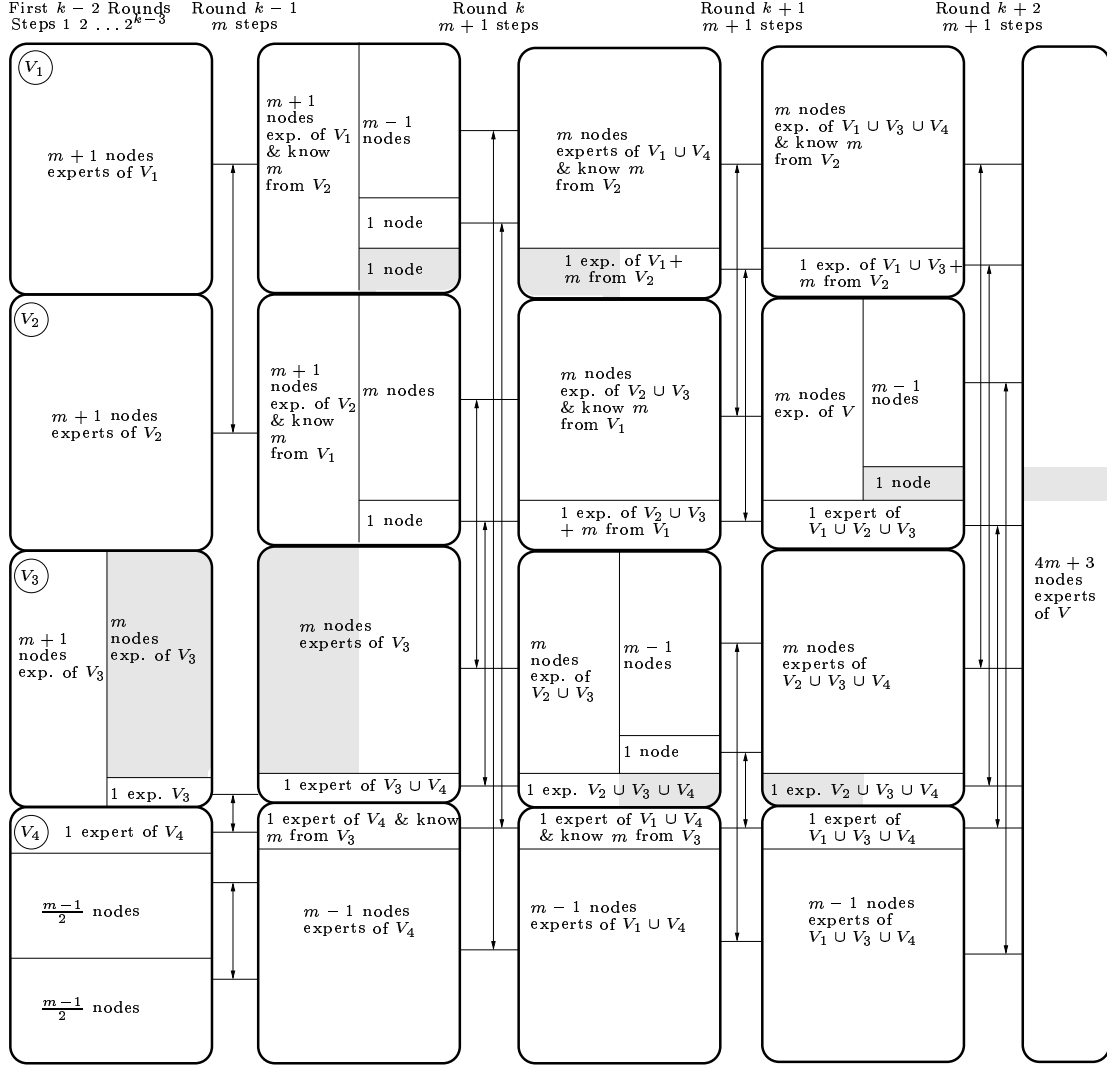

Figure 1: Gossip Scheme following the Steps Sequence σ for $n = 2^k - 1$ and $r = 1$

The idea here is to divide the set V of n vertices into 2^d subsets of approximately the same size. Let us decompose n as follows : $n = m \cdot 2^d + q$, where $0 \leq q \leq 2^d - 1$. Hence we have q subsets of $(m + 1)$ vertices, and $2^d - q$ subsets of m vertices. Then, depending on the value of n , we use one of the two following steps sequence.

- n is in the Top Half. In that case, we use the steps sequence σ_T below :

$$\underbrace{1 \ 2 \ 4 \ \dots \ 2^{k-d-2}}_{k-d \text{ Rounds}} \ x_T \ \underbrace{(m+1) \ (m+1) \ (m+1) \ \dots \ (m+1)}_{r+d+1=2^d \text{ Rounds}}$$

where $x_T = m + 1 - 2^{k-d-1}$.

- n is in the Bottom Half. In that case, we use the steps sequence σ_B below :

$$\underbrace{1 \ 2 \ 4 \ \dots \ 2^{k-d-3}}_{k-d \text{ Rounds}} \ y_B \ (y_B + \text{odd}(m)) \ \underbrace{(m+1) \ (m+1) \ (m+1) \ \dots \ (m+1)}_{r+d+1=2^d \text{ Rounds}}$$

where $y_B = \frac{m+2-\text{odd}(m)-2^{k-d-2}}{2}$.

In every case, the total number of steps is equal to $(2^d + 1) \cdot m + 2^d + \text{bot}(n)$, with $m = \lfloor \frac{n}{2^d} \rfloor$.

One can see that the Basic Premise holds in both σ_T and σ_B . The missing part here to complete the proof is the algorithm which would show that it is possible to achieve gossiping within $k + 1 + r$ rounds, and respecting the corresponding steps sequence.

Remark 3

- We note that the Conjecture above is a generalization of Theorem 3, since the particular case $r = 1$ derives from the case $d = 2$;
- This general upper bound not only works for $r = 2^d - d - 1$, but also for any $2^d - d - 1 \leq r < 2^{d+1} - (d + 1) - 1$. For this, it suffices to add “empty” rounds to the first $R_{\min} + 2^d - d - 1$ ones.

3 Relaxing the condition on S_n

In this Section, we study the function $R_n(s)$ (for any positive integer s), corresponding to the optimal number of rounds for a gossip algorithm in a n -node network which uses $S_n = S_{\min} + s$ steps, where $S_{\min} = n$.

Property 1 $R_n(0) = n$.

Proof: We have seen in Section 2.1 that for any steps sequence, the Basic Premise must necessarily hold. That is, for any round $1 \leq i \leq R_n(0)$, we must have $\sum_{j=1, j \neq i}^{R_n(0)} |s_j| \geq n - 1$, where $|s_j|$ is the number of steps used in round j (with $1 \leq j \leq R_n(0)$). But we also know by definition that $\sum_{j=1}^{R_n(0)} |s_j| = S_n$. Since we suppose $S_n = S_{\min} = n$, we have $\sum_{j=1}^{R_n(0)} |s_j| = n$. Combining this equality with the previous inequality, we get $|s_j| = 1$ for any $1 \leq j \leq R_n(0)$. Hence $S_n = \sum_{j=1}^{R_n(0)} |s_j| = R_n(0) = n$. \square

Remark 4 Note that this proves that the lower bound given in Theorem 2 with $r = n - (k - 1)$ is tight. Indeed, in that case, choosing $\alpha = k$ gives us $S_n(n - (k - 1)) \geq n$ for all odd n . Note also that Fraigniaud and Peters have provided in [FP94] a gossip algorithm among n nodes where gossiping can be achieved in n rounds and n steps ; they proved that this gossip algorithm could be achieved in the cycle C_n for any (odd) n . This shows that the minimum number of edges for a graph in which a gossip algorithm among n nodes, with n rounds and n steps, can be achieved, is equal to n .

Theorem 4 For any $s \geq 1$, let $p = \lfloor \log_2(s + 1) \rfloor$ and $m = n + s - 2^{p+1} + 1$. Then we have :

$$R_n(s) \geq (p + 1) + \lceil \frac{m}{s + 1} \rceil$$

Proof : The proof relies on the same argument as Proof of Property 1 above. Indeed, the Basic Premise must hold for any chosen steps sequence. Here, we are going to give the “best” steps sequence in order to minimize the number of rounds, such that this steps sequence σ satisfies the Basic Premise.

First, for any steps sequence with $R_n(s)$ rounds, we must have $\sum_{i=1, i \neq j}^{R_n(s)} |s_i| \geq n - 1$ for any $1 \leq j \leq R_n(s)$. Since we suppose $S_n = n + s = \sum_{j=1}^{R_n(s)} |s_j|$, we conclude that for any $1 \leq j \leq R_n(s)$, $|s_j| \leq s + 1$. Hence we will choose a steps sequence σ with a maximum number of s_j such that $|s_j| = s + 1$. However, we know that for any $1 \leq j \leq R_n(0)$, $|s_j| \leq 2^{j-1}$ (because the number of informed vertices can at most double at each round). Hence, the first $p + 1$ rounds in σ will be $1 \ 2 \ 4 \dots \ 2^p$, where p is such that $2^p \leq s + 1 < 2^{p+1}$, that is $p = \lfloor \log_2(s + 1) \rfloor$.

Then, we have to make sure that $\sum_{j=1}^{R_n(s)} |s_j| = n + s$. Indeed, we need the following sequence σ :

$$1 \ 2 \ 4 \dots 2^p \ x \ (s+1) \ (s+1) \dots (s+1)$$

where x is the rest of the division between $m = (n+s) - (2^{p+1} - 1)$ and $s+1$, that is $0 \leq x < s+1$. However, if $x = 0$, then we can save one round by not including it in σ . In both cases (that is $x = 0$ as well as $x > 0$), we see that σ is the shortest sequence, in terms of rounds, that we could get. Now let us distinguish the two cases :

- $x = 0$. In that case, this means that the smallest number of rounds we could get, say R' , satisfies : $2^{p+1} - 1 + (R' - (p+1)) \cdot (s+1) = n + s$. From this, since $R_n(s) \geq R'$, we conclude $R_n(s) \geq (p+1) + \frac{m}{s+1}$.
- $x > 0$. In that case, R' satisfies : $2^{p+1} - 1 + x + (R' - (p+2)) \cdot (s+1) = n + s$. Since $R_n(s) \geq R'$, we conclude $R_n(s) \geq (p+1) + \lceil \frac{m}{s+1} \rceil$.

Collectively, the two cases $x = 0$ and $x > 0$ imply the result. \square

Remark 5 *The case $s = 1$ gives $R_n(1) \geq \frac{n+3}{2}$ by Theorem 4. We can see that this bound is tight in the cases $n = 5$, $n = 7$ and $n = 9$, thanks to Figures 2 and 3 below. (In these Figures, each horizontal line represents one node and the numbers in the boxes indicate the information received during the communication immediately to the left. For example, take Figure 2 (left) : in round 4, node 5 sends items 1 and 5 to node 3 and receives item 3. Shading indicates that a node was idle during the round). These optimality results lead to the following Conjecture.*

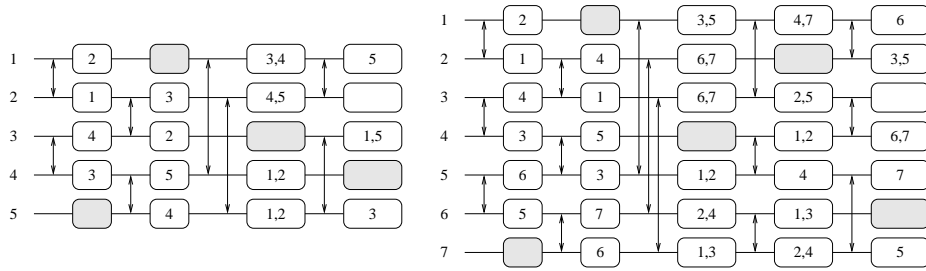

Figure 2: Gossiping among 5 vertices in 4 rounds and 6 steps (left) among 7 vertices in 5 rounds and 8 steps

Conjecture 2 *For all odd $n \geq 5$, $R_n(1) = \frac{n+3}{2}$.*

The above Conjecture is motivated by the fact that it is true for any $n \in \{5, 7, 9\}$, but also the following : we have seen that Theorem 4 applied to the case $s = 1$ implies that any gossip algorithm that takes $n + 1$ steps takes at least $\frac{n+3}{2}$ rounds. But we also see, thanks to Theorem 2, that if we suppose we allow $\frac{n+3}{2}$ rounds (that is $r = \frac{n+3}{2} - (k+1)$), then the upper bound on $S_n(r)$ given by Theorem 2 is the following ; $S_n(r) \geq n + 1$. It suffices for this to take $\alpha = k - 1$.

We also note that the lower bound for $R_n(s)$ given in Theorem 4 is tight for an infinite number of cases. This is the purpose of Propositions 2 and 3 below.

Proposition 2 *Let n be an odd integer such that $\lceil \log_2(n) \rceil = k$.*

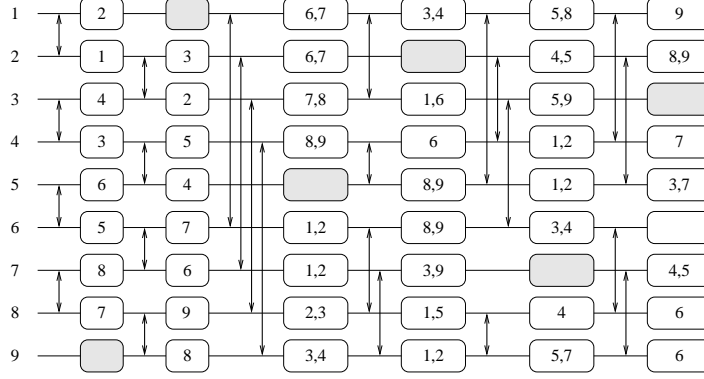

Figure 3: Gossiping among 9 vertices in 6 rounds and 10 steps

- For all n in the Bottom Half and $s = \lfloor \frac{n-2^{k-2}}{2} \rfloor$, the lower bound on $R_n(s)$ given by Theorem 4 is tight.
- For all n in the Top Half and $s = n - 2^{k-1} - 1$, the lower bound on $R_n(s)$ given by Theorem 4 is tight.

Proof : Thanks to the results of [FP98a], we know that (cf. Theorem 1) :

- For all n in the Bottom Half, $R_n(\lfloor \frac{n-2^{k-2}}{2} \rfloor) = k + 1$.
- For all n in the Top Half, $R_n(n - 2^{k-1} - 1) = k + 1$.

If we consider the general lower bound given by Theorem 4, we can see that it is tight in both cases.

- If n is in the Bottom Half, then let us compute $R_n(s)$ with $s = \lfloor \frac{n-2^{k-2}}{2} \rfloor$. In that case, we see that $2^{k-3} \leq s \leq 2^{k-2} - 1$. Hence, we have to distinguish two cases :
 - $s + 1 = 2^{k-2}$, that is $n = 3 \cdot 2^{k-2} - 1$. In that case, $p = k - 2$, and Theorem 4 yields $R_n(s) \geq k - 1 + \lceil \frac{m}{s+1} \rceil$, where $m = 2^{k-1} - 1$ and $s + 1 = 2^{k-2}$. Hence we have $R_n(s) \geq k + 1$, and the bound is tight.
 - $s + 1 \neq 2^{k-2}$. In that case, we have $p = k - 3$, and $\frac{m}{s+1} = 3 - \frac{2}{n-2^{k-2}+1}$, that is $\lceil \frac{m}{s+1} \rceil = 3$. Hence $R_n(s) \geq k + 1$, and the bound is also tight.
- If n is in the Top Half and if we consider $s = n - 2^{k-1} - 1$, we have $2^{k-2} \leq s \leq 2^{k-1} - 2$. In that case, $p = k - 2$, and $\lceil \frac{m}{s+1} \rceil = \lceil \frac{2n-2^k}{n-2^{k-1}} \rceil = 2$. Hence, $R_n(s) \geq k + 1$, and the lower bound appears to be tight as well.

□

Proposition 3 For all $n = 2^k - 1$ and $s = 2^{k-2} - 1$ with $k \geq 3$, the lower bound on $R_n(s)$ given by Theorem 4 is tight.

Proof : When $n = 2^k - 1$ and $R_n = R_{min} + 1 = k + 2$, we know by Proposition 1 that $S_n(1) = 5 \cdot 2^{k-2} - 2$. Now suppose we fix S_n to be $S_n = S_{min} + (2^{k-2} - 1)$, that is $S_n = S_n(1)$. In that case, we know that $R_n(2^{k-2} - 1) = k + 2$. Now, let us show that the lower bound on $R_n(2^{k-2} - 1)$ given by Theorem 4 is tight.

Indeed, in that case $s = 2^{k-2} - 1$, and we get $p = \lfloor \log_2(s + 1) \rfloor = k - 2$. Moreover, $m = n + s - 2^{p+1} - 1 = 3 \cdot 2^{k-2} - 1$. This means that $\lceil \frac{m}{s+1} \rceil = \lceil 3 - \frac{1}{2^{k-2}} \rceil$. Since $k \geq 3$, we have $\lceil \frac{m}{s+1} \rceil = 3$. Hence, the lower bound on $R_n(s)$ given by Theorem 4 yields $R_n(s) \geq (k - 2) + 1 + 3$; this show that the bound is tight. □

4 Summary of the Results for the Synchronous Case

A summary of the results in the synchronous case is given in Tables 2 and 1 below. In each row, for the values of r (resp. s) and n which are given respectively in the first and second column, we give the known lower and upper bound on $S_n(r)$ (resp. $R_n(s)$). We assume in these tables that $k = \lceil \log_2(n) \rceil$. The ‘‘Optimality’’ column indicates the optimality, and gives the corresponding reference.

| $S_n(r)$ | | | | |
|---------------|--------------------------------|---|---|---------------|
| s | n | Lower Bound | Upper Bound | Optimality |
| 0 | $\forall n$ in the Bottom Half | $n + \lfloor \frac{n-2^{k-2}}{2} \rfloor$ | $n + \lfloor \frac{n-2^{k-2}}{2} \rfloor$ | Yes (Rem. 1) |
| 0 | $\forall n$ in the Top Half | $2n - 2^{k-1} - 1$ | $2n - 2^{k-1} - 1$ | Yes (Rem. 1) |
| 1 | $\forall n$ in the Bottom Half | Formulae of Theorem 2 | $5 \cdot \lceil \frac{n}{4} \rceil + 4$ (Theorem 3) | |
| 1 | $\forall n$ in the Top Half | Formulae of Theorem 2 | $5 \cdot \lceil \frac{n}{4} \rceil + 5$ (Theorem 3) | |
| 1 | $n = 2^k - 1$ | $5 \cdot 2^{k-2} - 2$ | $5 \cdot 2^{k-2} - 2$ | Yes (Prop. 1) |
| s | $\forall n$ | Formulae of Theorem 2 | | |
| $n - (k + 1)$ | $\forall n$ | n | n | Yes (Rem. 4) |

Table 1: Summary of the results for $S_n(r)$

| $R_n(s)$ | | | | |
|---------------------------------------|--------------------------------|---|-------------|---------------|
| s | n | Lower Bound | Upper Bound | Optimality |
| 0 | $\forall n$ | n | n | Yes (Prop. 1) |
| 1 | $\forall n$ | $\frac{n+3}{2}$ | | |
| s | $\forall n$ | $p + 1 + \lceil \frac{n+s-2^{p+1}+1}{s+1} \rceil$ where $p = \lfloor \log_2(s+1) \rfloor$ (Theorem 4) | | |
| $2^{k-2} - 1$ | $n = 2^k - 1$ | $k + 2$ | $k + 2$ | Yes (Prop. 3) |
| $\lfloor \frac{n-2^{k-2}}{2} \rfloor$ | $\forall n$ in the Bottom Half | $k + 1$ | $k + 1$ | Yes (Prop. 2) |
| $n - 2^{k-1} - 1$ | $\forall n$ in the Top Half | $k + 1$ | $k + 1$ | Yes (Prop. 2) |

Table 2: Summary of the results for $R_n(s)$

5 Discussion of the Results and Conclusion

Thanks to the results above, we can give some quantitative results, especially concerning $S_n(r)$.

Indeed, since we have seen that $S_n(1) \leq 5 \lceil \frac{n}{4} \rceil + 4 + \text{bot}(n)$, and since we know $S_{\min} = n$, we can see that the ratio $Q_{1,\min}^S = \frac{S_n(1)}{n}$ is, asymptotically, of order $\frac{5}{4} + o(1)$. That is, using only one round more than the optimal ensures us to use at most 25% more steps than the optimal.

Note also that when $n = 2^k - 1$, we see, thanks to Theorem 2, that $S_n(2) \geq 19 \cdot 2^{k-4} - 2$. Since

we have $S_n(2) \leq S_n(1) = 5 \cdot 2^{k-2} - 2 = 20 \cdot 2^{k-4} - 2$, we see that the ratio $Q_{2,1}^S = \frac{S_n(2)}{S_n(1)}$ satisfies asymptotically : $.95 \leq Q_{2,1}^S \leq 1$, that is we do not gain more than 5% (in terms of steps) in the case $n = 2^k - 1$ when increasing the number of rounds from 1 to 2.

In this paper, we have provided a collection of results concerning the trade-offs between the number of steps and the number of rounds for a gossip algorithm among n nodes, n being odd. However, there remains many unsolved and interesting problems concerning these trade-offs. Among these open problems, we would like to point out the following one : we strongly believe that the general lower bound given on $S_n(r)$ in Theorem 2 (resp. on $R_n(s)$ in Theorem 4) is, in fact, optimal for all r (resp. s) and odd n . Indeed, we have seen that it is tight in many cases (cf. Tables 1 and 2), and there are also several particular cases for which the bound is tight. However, proving the tightness of this lower bound seems to be a very difficult problem.

References

- [FP94] P. Fraigniaud and J.G. Peters. Minimum linear gossip graphs and maximal linear (Δ, k) -gossip graphs. Technical Report CMPT TR 94-06, Simon Fraser University, Burnaby, B.C., 1994. Available at <http://fas.sfu.ca/pub/cs/techreports/1994/>.
- [FP98a] G. Fertin and J.G. Peters. Optimal odd gossiping. Technical Report CMPT TR 1998-24, Simon Fraser University, Burnaby, B.C., December 1998. Submitted for publication.
- [FP98b] G. Fertin and J.G. Peters. Odd gossiping in the linear cost model. *Proc. Workshop on Communication - 23rd Int. Symp. on Mathematical Foundations of Computer Science (MFCS), Brno, Czech Republic*, August 1998.
- [Kn75] W. Knödel. New gossips and telephones. *Discrete Mathematics*, 13:95, 1975.
- [PRX96] J.G. Peters, L. Raabe, and C. Xu. Odd gossiping. 1996. Manuscript.

6 Annex for the Referees : Proof of Theorem 3

We recall that we suppose n in the Top Half, $r = 1$, and we want to prove that it is possible to gossip among n nodes using the following steps sequence :

$$\underbrace{1 \ 2 \ 4 \ \dots \ 2^{k-4}}_{k-3 \text{ Rounds}} \ x_T \ (m+1) \ (m+1) \ (m+1) \ (m+1)$$

where $x_T = m + 1 - 2^{k-3}$.

We prove that Condition **(C3)** of Proof of Theorem 3 always holds in the Top Half. For this, we use the following argument : each V_i of even (resp. odd) cardinality gossips within its own subset during the first $k - 2$ (resp. $k - 1$) rounds, respecting the above sequence of steps. We know that, in each of the set(s) of odd cardinality, there exists at least a vertex $u_i \in V_i$ which is idle at round $k - 1$. Hence, u_i is expert of V_i after round $k - 2$, and it can communicate with a vertex of another subset V_j . This is also true for the set(s) of even cardinality : each vertex of such a set is expert of its own subset after round $k - 2$. Hence, during round $k - 1$ it is possible for each of them to communicate with vertices of other subsets.

For each of the four cases ($n = 4m + 1$ or $n = 4m + 3$, even m or odd m), Figures 4 to 7 show an *ad hoc* gossip algorithm which achieves gossiping in $k + 2$ rounds, and with the required sequence of steps. In each of the Figures, the column of 4 boxes with bold outlines on the left shows the situation after $k - 2$ rounds. Rounds $k - 1$ to $k + 2$ are shown in detail and the box on the right shows the situation after round $k + 2$. The gray shading is used to indicate nodes that are idle during a round.

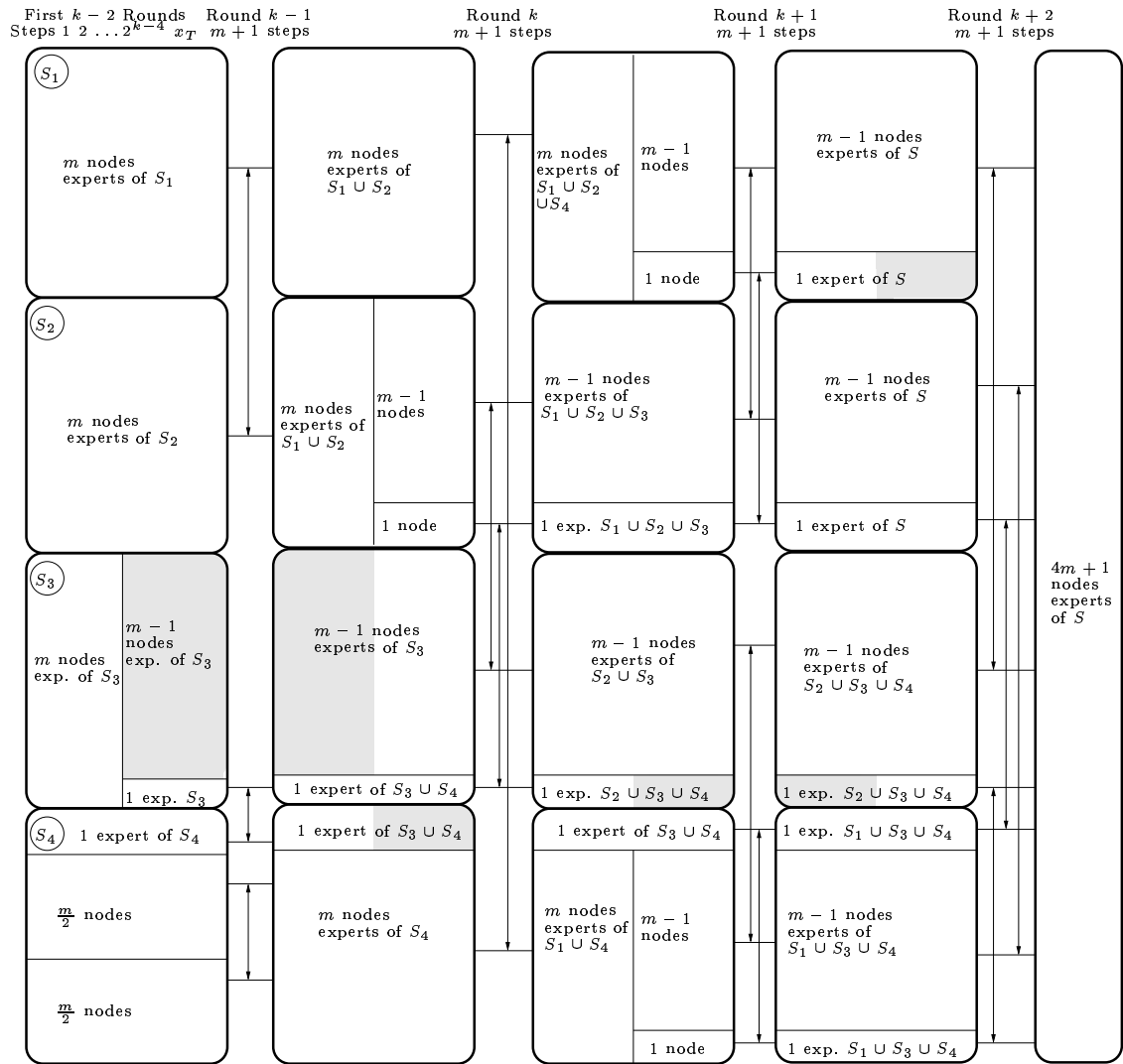

Figure 4: $n = 4m + 1$ in the Top Half with even m

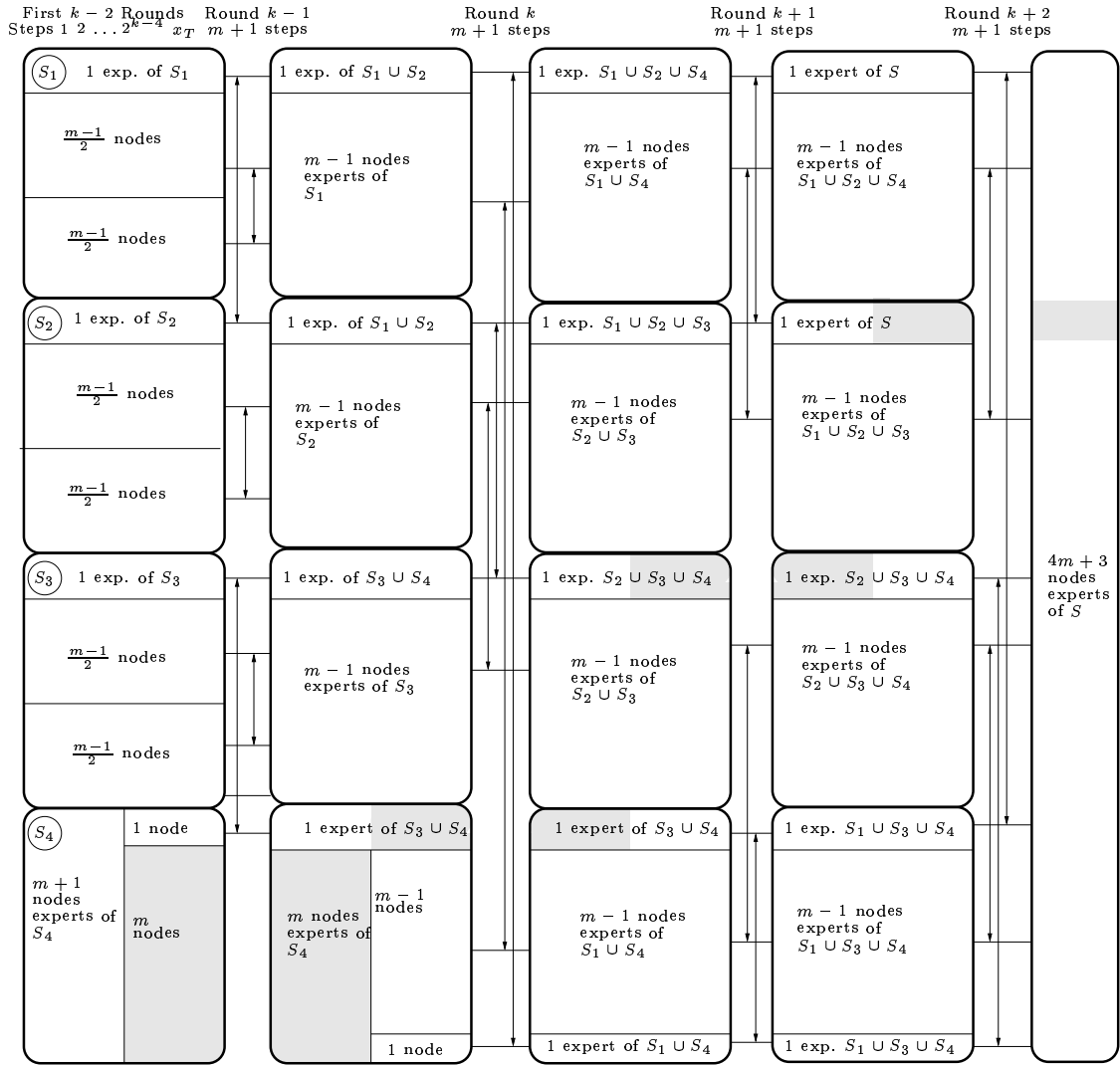

Figure 5: $n = 4m + 1$ in the Top Half with odd m

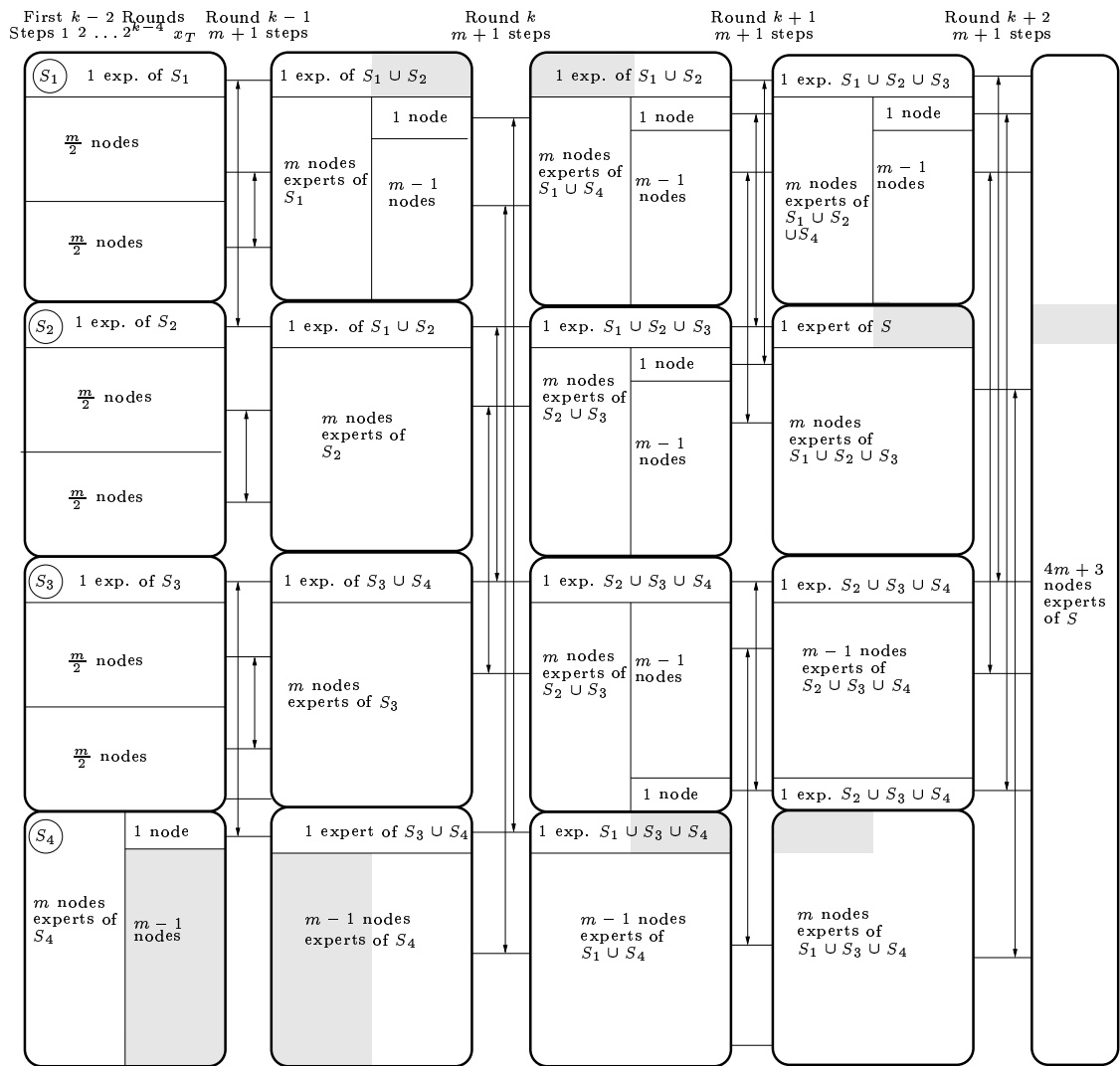

Figure 6: $n = 4m + 3$ in the Top Half with even m

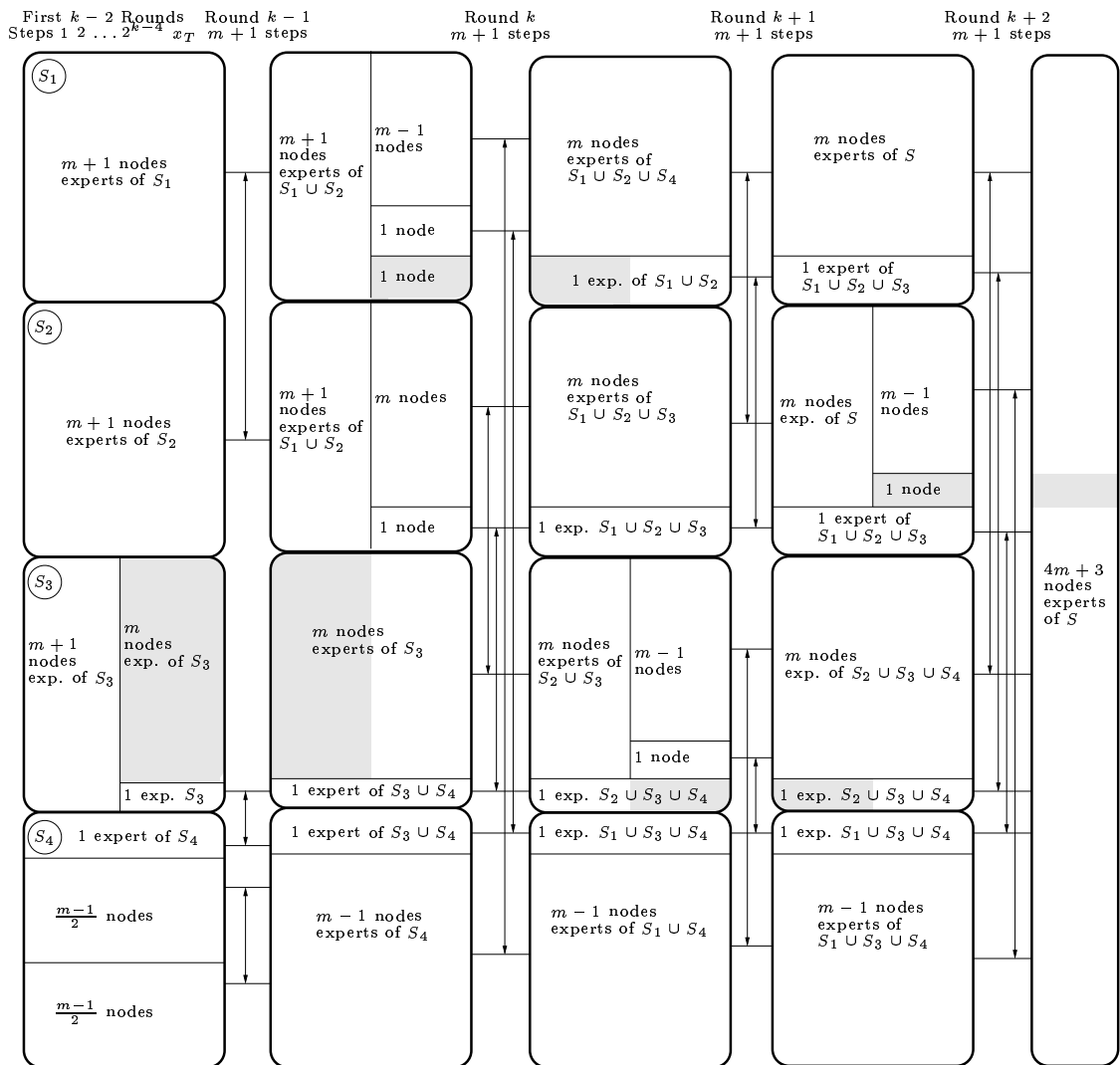

Figure 7: $n = 4m + 3$ in the Top Half with odd m